

CB25 Large Condensate Pump



Beckett's family of large condensate pumps is ideal for higher volume condensate removal applications. Each pump operates quietly, efficiently and offers such features as a built-in safety switch and a one gallon tank. Power connection is hard wired with an UL rated terminal block. All pumps are UL/CUL listed. This unit is capable of handling acidic condensation from condensing furnaces and tankless water heaters.

FEATURES

- Available in 115, 230
- 25 ft. max lift
- 3/8" OD copper discharge
- 1.1" diameter inlet with 5/8" ID grommet
- HT models rated up to 212 degrees F
- 1 gallon tank capacity
- Automatic on/off operation with separate overflow detection switch
- Thermally protected fan cooled motor

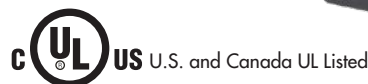

Model #	H	W	L	Outlet O.D.	Inlet	Volts	Amps	Watts	Gallons per hour @ 60Hz / Rated Voltage				Shut Off (Ft.)	Weight Lb. Each	Safety Switch	Check Valve	UL US
									1'	5'	10'	20'					
CB251UL	10"	5.9"	12"	3/8"	1.1"	115	1.3	106	108	100	84	40	25'	7.1	✓	✓	✓
CB251ULHT	10"	5.9"	12"	3/8"	1.1"	115	1.3	106	108	100	84	40	25'	7.8	✓	✓	✓
CB252UL	10"	5.9"	12"	3/8"	1.1"	230	0.9	125	108	100	84	40	25'	7.0	✓	✓	✓
CB252ULHT	10"	5.9"	12"	3/8"	1.1"	230	0.9	125	108	100	84	40	25'	7.8	✓	✓	✓

Average Performance

Beckett Automatic Condensate Units Coding Legend:

1- 115V 2- 230V
HT- High Temperature Unit 190°F Max. Water Temp.

Tank Capacity:

CB25 1 US gallon (3.785 Liters)

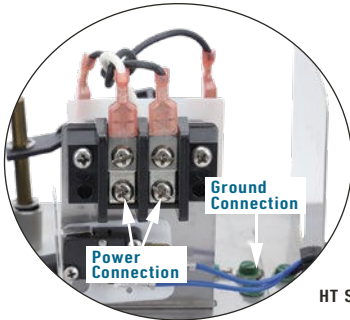
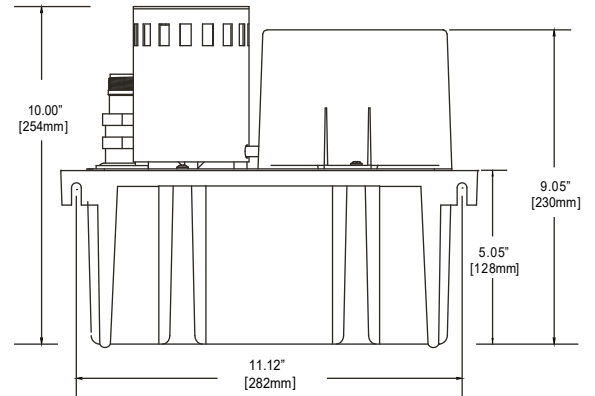
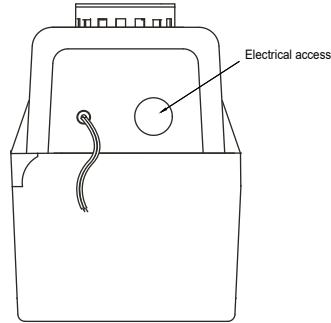
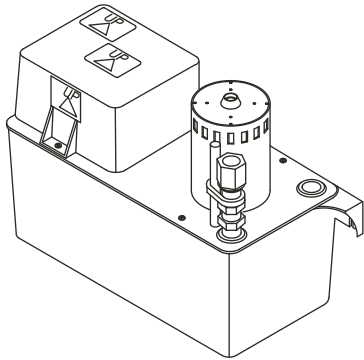

HT Series

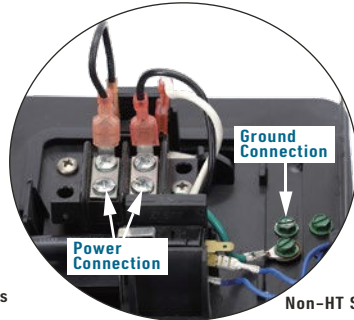

Non-HT Series

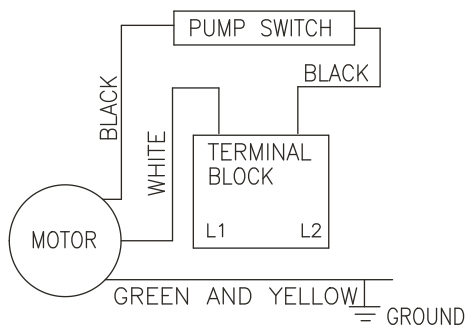
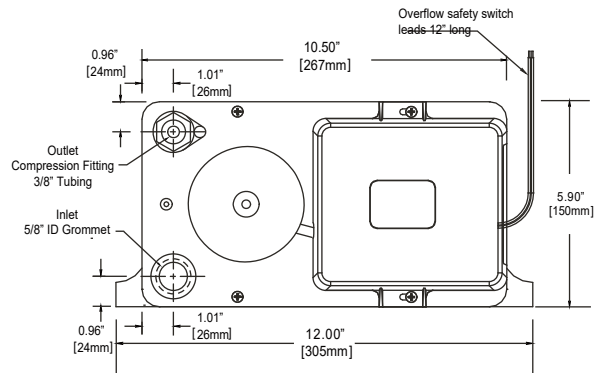

WIRING DIAGRAM

