



# CB50 & CP65

## Heavy Duty Large Condensate Pump

Beckett's heavy-duty pump series is capable of handling all your industrial applications. Its robust design promotes a more efficient, quieter operation while maintaining product durability. The pump comes with a built-in safety switch, a one gallon tank, replaceable check valve and a pre-wired terminal block. Available in 115V, 230V and 460V models. HT (High temp) models can handle condensate temperatures up to 212 F. This unit is capable of handling acidic condensation from condensing furnaces and tankless water heaters.

### FEATURES

- Available in 115, 230, 460V
- 50 ft. and 65 ft. max lift
- 1/2" OD copper discharge
- 1.25" diameter inlet with 5/8" ID grommet
- HT models rated up to 212 degrees F
- 1 gallon tank capacity
- Automatic on/off operation with separate overflow detection switch
- Thermally protected fan cooled motor

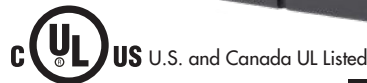

CB50 Series



CP65 Series

Model #	H	W	L	Outlet O.D.	Inlet	Volts	Amps	Watts	Gallons per hour @ 60Hz / Rated Voltage								Shut Off (Ft.)	Weight Lb. Each	Safety Switch	Check Valve	cULus
									1'	5'	10'	15'	20'	30'	40'	50'					
CB501UL	10"	5.9"	12"	1/2"	1.25"	115	4.0	300	476	441	396	351	306	216	126	-	50'	11.6	✓	✓	✓
CB501ULHTS	10"	5.9"	12"	1/2"	1.25"	115	4.0	300	476	441	396	351	306	216	126	-	50'	12.3	✓	✓	✓
CB502UL	10"	5.9"	12"	1/2"	1.25"	230	1.9	350	486	453	412	372	337	249	168	-	50'	11.7	✓	✓	✓
CB502ULHTS	10"	5.9"	12"	1/2"	1.25"	230	1.9	350	486	453	412	372	337	249	168	-	50'	12.4	✓	✓	✓
CB504UL	10"	5.9"	12"	1/2"	1.25"	460	0.8	350	420	380	355	330	310	240	145	-	50'	12.2	✓	✓	✓
CB504ULHTS	10"	5.9"	12"	1/2"	1.25"	460	0.8	350	420	380	355	330	310	240	145	-	50'	13.0	✓	✓	✓
CP651ULHTS	10 1/2"	5.9"	12"	1/2"	1.25"	115	3.3	375	476	-	430	-	380	330	270	200	65'	13.9	✓	✓	✓
CP654ULHTS	10 1/2"	5.9"	12"	1/2"	1.25"	460	0.89	390	476	-	430	-	380	330	270	200	65'	15.0	✓	✓	✓

Average Performance

#### Beckett Automatic Condensate Units Coding Legend:

1- 115V 2- 230V 4- 460V  
HTS- High Temperature Unit 212°F Max. Water Temp.

#### Tank Capacity:

CB50, CP65 . . . . . 1 US gallon (3.785 Liters)

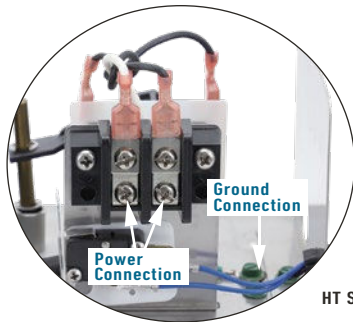
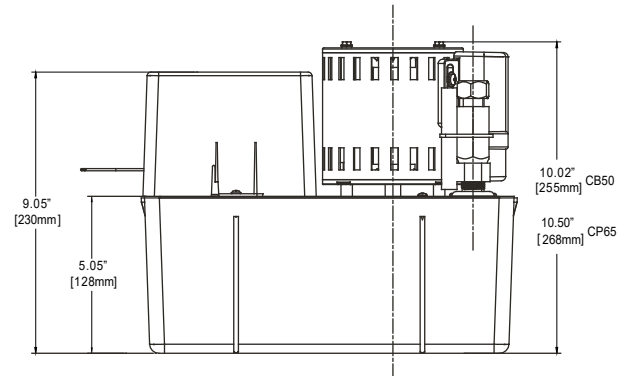
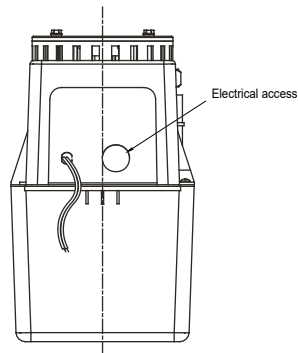
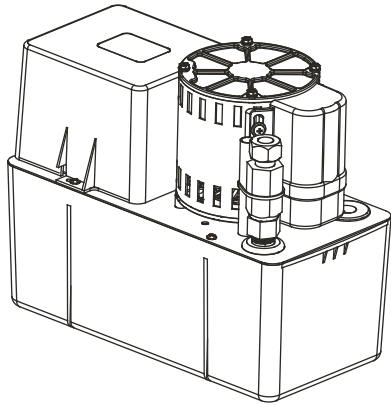

HT Series

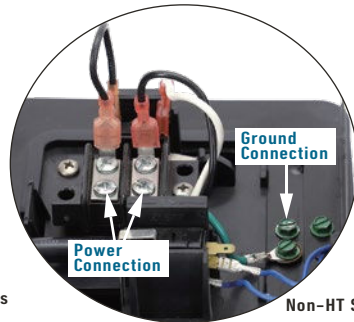

Non-HT Series

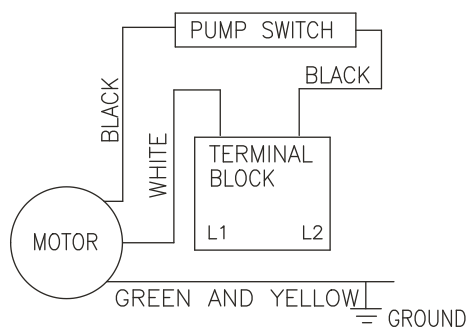
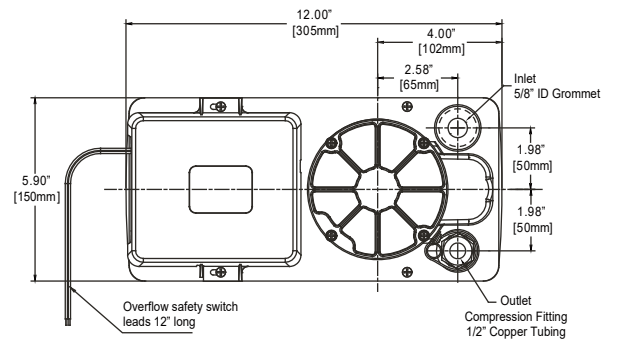

**WIRING DIAGRAM**

