

NEUTRALIZER CONDENSATE PUMP

115V, 22 Foot Max Lift

Beckett BK221TULN Neutralizer Condensate Pump is a simple and easy-to-install solution to safely treat acidic condensate produced by high efficiency furnaces, boilers, and water heaters.

The following codes require that acidic condensate be treated to avoid damaging cast iron and concrete sewer pipe before draining into sewage systems: International Plumbing Code (IPC) Section 803.1 and , National Standard Plumbing Code (NSPC 9.4.1), EPA Clean Water Act (Section 403.5(b)(2))

- Rated for appliances up to 500,000 btu/hr
- Easy install features: twist lock check valve, bubble level on lid, lift to test tab, heavy duty wall mounting tabs, top or side intake
- Easy to visually check and replace pre-bagged neutralizer media
- 1 Year warranty, class leading tank/cycle capacity
- Max water temperature 150°F
- Includes overflow safety switch & 20' of 3/8" ID tubing

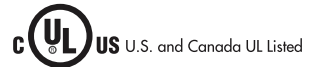
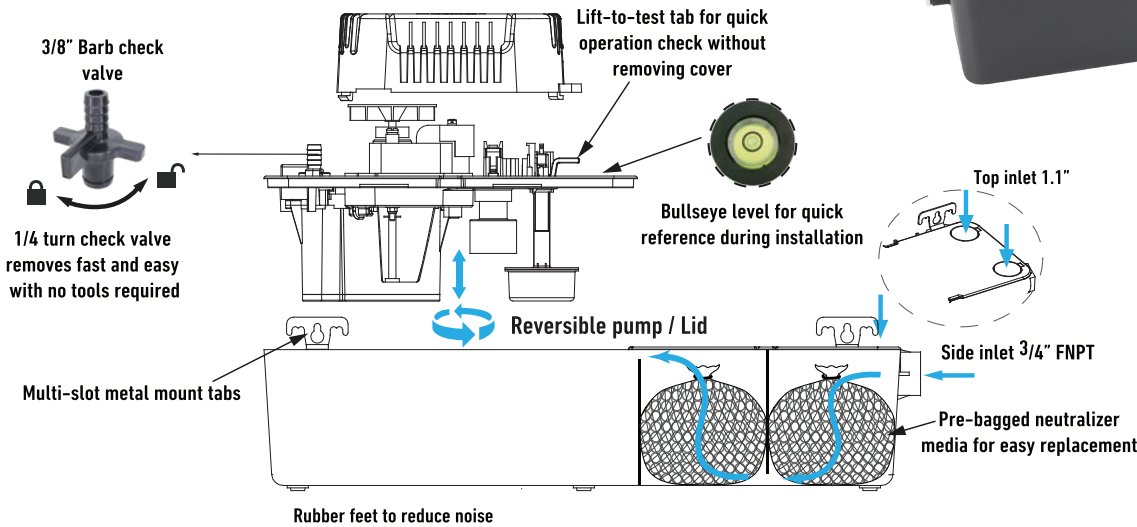

Model	Rated	Volts -Hz	Amps-Watts	Weight	Flow (GPH)@			Max lift	Outlet	Acidic Inlet		Tubing
					1'	10'	15'			Top	Side	
BK221TULN	500,000 btu/hr	115-60	1.2-65	4.8 lbs	125	83	50	22'	3/8" Barb	2 x 1.1"	1 x 3/4" FNPT	3/8" ID x 20' clear PVC

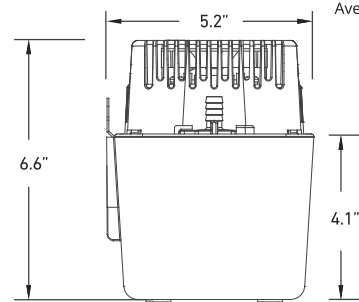
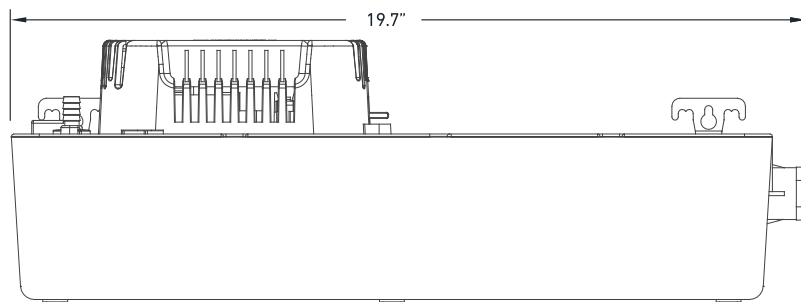

Average Performance



Neutralizer Condensate Pump Battle Card

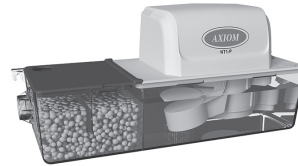

	Beckett BK221TULN	Axiom NT1-P	Little Giant VCMA-NPTC
Max Lift	22'	21'	20'
Flow @ 1'	125 GPH	90	85
Rated	500k BTU	500k BTU	500k BTU
Electrical	115V 1.2A 65 Watts	120V 1.6A 90 Watts	115V 1.5A 93 Watts
Length x Width x Height	19.7" L x 5.2" W x 6.6" H	15.8" L x 5.3" W X 7.0" H	19" L x 5.0" W x 7.0" H
Regulatory	UL CUL	ETL	UL CUL
Max Water Temp	150° F	140 F	140 F
Safety Overflow Switch	Yes	Yes	No
Tubing Included	Yes, 20' 3/8" ID Clear	Yes, 20' 3/8" ID Clear	No
Tank Capacity	3.6 qts	3.5 qts	4 qts
Side & Top Inlet	Yes	Yes	No, 1 Top Only
Wall Mount Tabs	Stainless Steel Tabs With 3 Widths	Plastic Tabs With 1 Width	Plastic Tabs With 1 Width
Water Pumped (Per Cycle)	42 Oz	24 Oz	22 Oz
Neutralizer Media Weight	4.1 Lbs	3.6 Lbs	4.8 Lbs
N Media Type	Sphere 3/8" Diameter	Sphere 3/8" Diameter	Gravel + Dust
Maintenance	Easy To Handle Mesh Media Bags	Loose Media, Hard to Replace	Mesh Fabric Sock
Warranty	1 Year	2 Year	1 Year



Replacement Neutralizer Media P/N: RM4

- pH treatment media refill for condensate neutralizer pumps used with high efficiency condensing furnaces and water heaters
- Media service life is one year or when pH falls below local permit zone
- Designed for use with Beckett BK221TULN pump or other neutralizer pumps rated up to 500k btu
- 3/8" ball media in two mesh bags for easy handling

BeckettUS.com



Condensate Pumps

beckettus.com
sales@beckettus.com
(866) 466-4319